

平成30年6月8日現在

機関番号：82401

研究種目：基盤研究(C) (一般)

研究期間：2015～2017

課題番号：15K08535

研究課題名(和文) Runx-mediated regulation of chemokine CCL5 for lung diseases

研究課題名(英文) Runx-mediated regulation of chemokine CCL5 for lung diseases

研究代表者

SEO WOOSOOK (Seo, Wooseok)

国立研究開発法人理化学研究所・統合生命医科学研究センター・研究員

研究者番号：40574116

交付決定額(研究期間全体)：(直接経費) 3,500,000円

研究成果の概要(和文)：CCL5ケモカインは多くの炎症性疾患の発症に関係している。CCL5の制御機構を理解するために、私はRunx/CBF β 転写因子のノックアウトマウスを検査し、Runx/CBF β 欠損細胞はCCL5の発現が大幅に増加されていることを発見した。これはCCL5がRunx/CBF β によって転写制御されていることを示している。通常のChIPと新しいenChIPアッセイを組み合わせることによって、CCL5発現がアクティベーション状態によって2つの異なるエンハンサーを必要とすることがわかった。これらのエンハンサーは、T細胞由来のCCL5発現およびT細胞免疫反応に不可欠であった。

研究成果の概要(英文)：CCL5 chemokine is related to the development of many inflammatory diseases. To understand how CCL5 is regulated, I have examined a knockout mouse of Runx/CBF β transcription factor and discovered that CCL5 is hugely upregulated in the absence of Runx/CBF β . This indicated that CCL5 is tightly regulated by Runx/CBF β . By combining regular ChIP and novel enChIP assays, I discovered that CCL5 expression requires two separate enhancers depending on activation states. These enhancers are crucial for proper expression of CCL5 from T cells as well as T-cell immunity.

研究分野：免疫学

キーワード：アレルギー 免疫関連疾患

1 . 研究開始当初の背景

Abnormal expression of chemokine CCL5 from immune cells is related to the development many diseases, but the regulatory mechanisms for CCL5 expression is not well understood so far. Interestingly, we discovered that Runx/CBF transcription factor complexes suppress CCL5 in normal situation to avoid uncontrolled expression of CCL5 which can be pathogenic to hosts. Based on this discovery, we aimed to decipher the molecular mechanisms of CCL5 regulation by elucidating the genomic regions in which Runx/CBF binds to control CCL5.

2 . 研究の目的

(1) Finding cis-regulatory regions of CCL5 gene bound by Runx/CBF : Phenotypical analysis of Runx/CBF -deficient mice indicated that CCL5 is repressed by Runx/CBF since the removal of Runx/CBF proteins from T cells resulted in the huge upregulation of CCL5. By combining both conventional and novel ChIP (Chromatin immunoprecipitation) assays, we aimed to identify the cis-regulatory regions where Runx/CBF binds around CCL5 locus.

(2) Characterization of identified cis-regulatory elements: Since cis-elements are crucial for the determination of stage- and cell-type-specificities of gene expression, identified cis-elements of CCL5 were to be carefully examined by various methods. By generating knockout mice for the identified cis-elements, physiological roles of the regions can be examined in detail. This would allow us to understand how CCL5 is regulated in vivo.

3 . 研究の方法

Since our preliminary data indicated that Runx/CBF regulates CCL5 expression, we expected that Runx/CBF binds on several places around CCL5 locus to directly

regulate it. Therefore, it was normal to find many Runx/CBF binding sites by conventional ChIP-seq. Therefore, more approaches are necessary to find important cis-elements.

Therefore, one novel variants of ChIP named as enChIP (originally developed by Hodaka Fujii at the Osaka University) was applied in addition to conventional ChIP. In enChIP, deactivated Crispr/Cas9 is directed to CCL5 promoter by gRNA, then an antibody against Crispr/Cas9 is used to pull-down DNAs associated with CCL5 promoter (Fig 1). This approach can efficiently identify more physiologically relevant DNA fragments interacting with CCL5 promoter. Another complementary approach is to use 3C (Chromatin Conformation Capture) assays to confirm the physiological interaction between CCL5 promoter and newly discovered cis-elements.

4 . 研究成果

(1) CCL5 is regulated by transcription complex Runx/CBF

Analysis of Runx/CBF -deficient mice clearly showed that several chemokines are highly upregulated. We especially focused

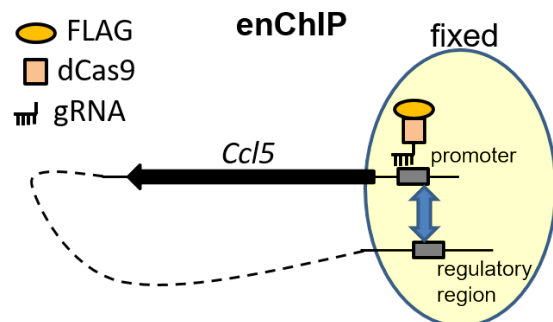

Figure 1

on CCL5 among Runx/CBF targets since CCL5 has been implicated numerous diseases such as human asthma. Indeed, we observed that Runx/CBF -deficient mice have inflamed lungs similarly to human asthma patients. These results illustrated that Runx/CBF

plays important roles in the regulation of CCL5

(2) CCL5 requires a nearby enhancer during the steady state

CCL5 is expressed mostly from T cells and NK cells. During the steady state, only memory T cells express a certain amount of CCL5 which is important for the maintenance of local immunity at various tissue sites such as skin and lungs. Our ChIP-seq results of Runx/CBF transcription factor showed a strong peak about 5 kb upstream from the CCL5 promoter (Figure 2).

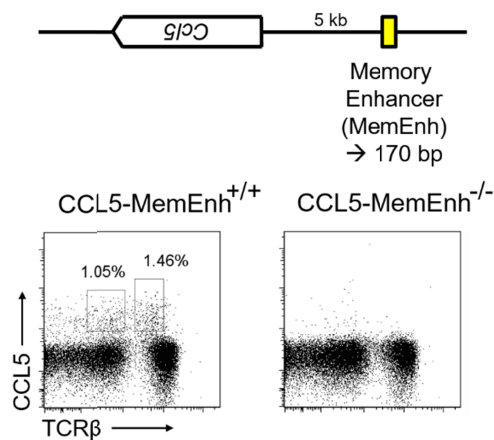

Figure 2

By generating knockout mice for this region, we observed a total loss of CCL5 from memory T cells (thus named as CCL5 memory enhancer).

(3) BAC transgenic study

For a better monitoring of CCL5 in vivo, we have generated BAC (Bacterial Artificial Chromosome) transgenic mice in which CCL5 gene was replaced by GFP (Green fluorescent protein). We confirmed that this transgenic mouse line accurately represents the expression patterns of endogenous CCL5. Interestingly, this transgenic mouse cells failed to maintain GFP after in vitro stimulation (Figure 3), indicating that

CCL5 might use another enhancer after activation in addition to memory enhancer (thus named as activation enhancer).

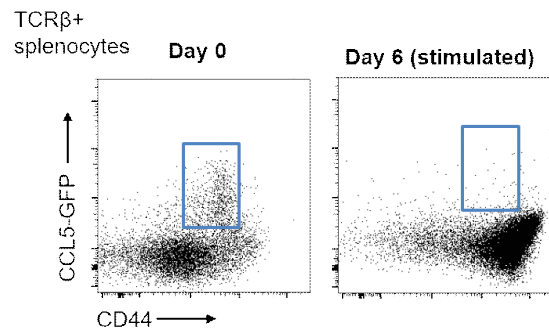

Figure 3

(4) enChIP to find an unknown enhancer

Our collaborator Hodaka Fujii at the Osaka University recently developed a novel technology called enChIP which is basically a combination of the traditional ChIP and Crispr/Cas9 system (Figure 1). In short, one can find a distant DNA area interacting with a gene of interest by expressing gRNA to the gene of interest and deactivated Cas9 which will be bound to gRNA. Since Cas9 is tagged by Flag, one can pulldown surrounding molecules around the gene of interest after fixation. By using this method, we have identified a long distant area (more than 1 Mb) which was interacting with CCL5 gene (Figure 4). This result was further confirmed by 3C assay.

Generation of knockout mice could confirm that this region is required for activated T cells to express CCL5, but not for steady-state memory T cells. This clearly showed that enChIP can be used to identify a novel DNA area which interacts with the gene of interest.

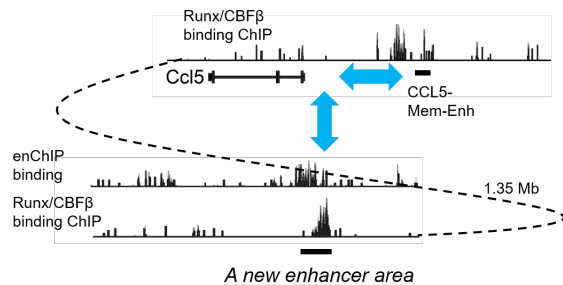

Figure 4

(5) Physiological function of dual enhancers

Our study showed that CCL5 expression is delicately regulated by two enhancers since overexpression of CCL5 results in inflammatory diseases and down-regulation of CCL5 results in inefficient immunity against pathogens. To test the functions of enhancers, we challenged enhancer knockout mice with human influenza virus, but they had no problems clearing virus, indicating that CCL5 expression supported by these enhancers do not play critical roles in the case of influenza. On the other hand, these knockout mice were a significantly more efficient in fighting with a certain cancer according to our preliminary result. Further study will be required to know the roles of CCL5 during cancer development.

5. 主な発表論文等

(研究代表者、研究分担者及び連携研究者には下線)

〔雑誌論文〕(計 6件)

① Kojo, S., Tanaka, H., Endo, T. A., Muroi, S., Liu, Y., Seo, W., Tenno, M., Kakugawa, K., Naoe, Y., Nair, K., Moro, K., Katsuragi, Y., Kanai, A., Inaba, T., Egawa, T., Venkatesh, B., Minoda, A., Kominami, R., Taniuchi, I. Priming of lineage-specifying genes by Bcl11b is required for lineage choice in post-selection thymocytes. *Nat. Commun.*, 2017, 8(1), 702. *Refereed.*

② Kakugawa K., Kojo S., Tanaka H., Seo W., Endo T., Katagawa Y., Muroi S., Tenno M., Yasmine N., Kohwi Y., Sakaguchi S., Kowhi-Shigematsu, T., Taniuchi I. Essential Roles of SATB1 in Specifying T Lymphocyte Subsets. *Cell Reports*, 2017, 19(6), 1176-1188. *Refereed.*

③ Seo W., Taniuchi I. Regulation of hematopoiesis and immune responses by long noncoding RNAs. *Int. Immunol.* 2017. *Refereed.*

④ Ebihara T., Seo W., Taniuchi I. Roles of RUNX Complexes in Immune Cell Development. *Adv Exp Med Biol.* 2017, 962, 395-413. *Refereed.*

⑤ Seo W., Muroi S., Akiyama K., Taniuchi I. Distinct requirement of Runx complexes for TCR enhancer activation at distinct developmental stages. *Sci. Rep.* 2017, 7, 41351. *Refereed.*

⑥ Seo W. and Taniuchi I. Transcriptional regulation of early T-cell development in the thymus. *Eur. J. Immunol.* 2016, 46 (3), 531-538. *Refereed.*

〔学会発表〕(計 5件)

① Seo W. & Taniuchi I. Regulation of CCL5 expression by Runx complexes and two stage-specific enhancers. 2017 日本免疫学会、仙台(日本)

② Seo W. & Taniuchi I. Control of T cell lineage decision by topological modulation of chromatin structures. 2016 日本免疫学会、沖縄(日本)

③ Seo W., Kojo S, Okeke A. & Taniuchi I. Regulation of CCL5 by Runx/CBF is essential to maintain lung homeostasis. 2016 国際免疫学会、メルボルン(オーストラリア)

④ Seo W. & Taniuchi I. Control of thymocyte fate decision by local chromatin

structure. 2015 日本分子生物学会、神戸（日本）. *Invited*.

⑤ Seo W. & Taniuchi I. Repression of CCL5 by Runx/CBFb is essential to prevent lung infiltration. 2015 日本免疫学会、札幌（日本）

〔図書〕（計 0 件）

〔産業財産権〕

出願状況（計 0 件）

名称：

発明者：

権利者：

種類：

番号：

出願年月日：

国内外の別：

取得状況（計 0 件）

名称：

発明者：

権利者：

種類：

番号：

取得年月日：

国内外の別：

〔その他〕

ホームページ等

6 . 研究組織

(1)研究代表者

セオ ウセオク（SEO, Wooseok）

国立研究開発法人理化学研究所・統合生命医科学研究センター・研究員

研究者番号：40574116

(2)研究分担者

（ ）

研究者番号：

(3)連携研究者

（ ）

研究者番号：

(4)研究協力者

（ ）